

Fractional TubeTrap™



- ◆ Corner, wall or ceiling mounted, bass trap
- ◆ Bass absorption to as low as 25Hz
- ◆ Treble diffusion above 400Hz
- ◆ Sturdy exoskeleton construction for strength
- ◆ Threaded inserts for stacking and hanging
- ◆ Fiber-free construction, multiple sizes and colors

Half Round and Quarter Round TubeTraps

The TubeTrap is the first and foremost corner loaded bass trap in the audio industry. It was only natural that ASC would adapt the same technology to fit flush into corners, walls and ceilings. Art Noxon, inventor of the revered TubeTrap, went to work on the physics and before long, the Fractional TubeTrap was born. Used mainly by audiophiles and recording engineers, the Fractional TubeTrap is used to fine tune room acoustics. Built-in diffusive wide angle treble backscattering above 400Hz and absorption down to 55Hz maintain room brightness and enhances detail and articulation as well as image resolution. ASC custom builds your Fractional just the way you want it, because no two rooms are exactly alike.



The Best Quality, Inside and Out



Nothing leaves our factory without extensive engineering and field testing. That said, our Fractional TubeTraps are often copied but never reproduced. Nobody matches ASC engineering or finish quality. You might think, what's the big deal? After we launched a major R&D effort to handle every acoustic issue, there are dozens of components in each unit. Each of these are hand made by our trained technicians here in Eugene Oregon.



Fractional TubeTrap Applications

Our Project Advisors might suggest the inclusion of Fractionals as part of an overall acoustic package. Fractionals are connectable and stackable and can be used practically anywhere you need acoustic control.

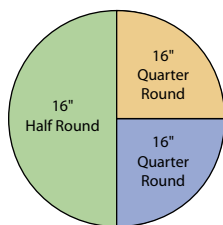

We often work with clients to customize and unify our product with their vision. You always get expert advice from folks who know audio acoustics inside and out. The end result is a win-win for everyone involved.



ASC ACOUSTIC SCIENCES CORPORATION

Headquarters:

4275 West 5th Ave.
Eugene, OR 97402

Contact:

Ph: 541.343.9727
Fax: 541.343.9245
info@tubetraps.com

www.acousticssciences.com

1 800 272 8823



Mounting Fractionals to Wall or Ceiling

Fractionals are always shipped complete with mounting hardware and install guide. Unless specified, they come standard ready for bracket mounting. This uses two custom sized brackets to support each end of your Fractional TubeTrap. The brackets are fastened to the Fractional using truss head screws.



Fractionals can also be ordered with "Z" Clip mounting for a small additional fee. This mounting method holds the Fractional extremely steady, minimizing any potential for rattle from high power audio blasts. This mounting method is a bit trickier to install properly, since everything has to line up just right. Our Pro Studio users love the "Z" Clip system.

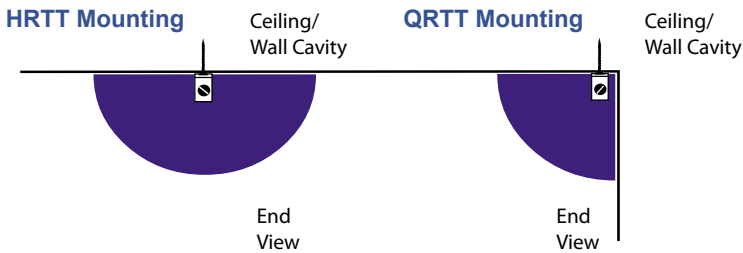

Custom Mounted Fractionals

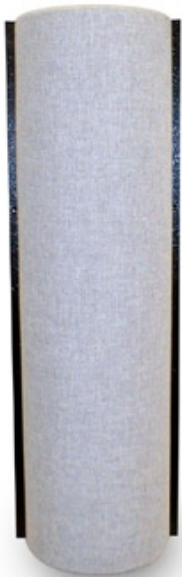

ASC has, over the years developed many different ways to mount Fractionals in special situations. Some people have unique rooms that require special techniques for attachment. Our engineers are always available to help with ideas and 25+ years of expertise. If you have a wall or ceiling that seems challenging, give ASC a call. We are here to help.

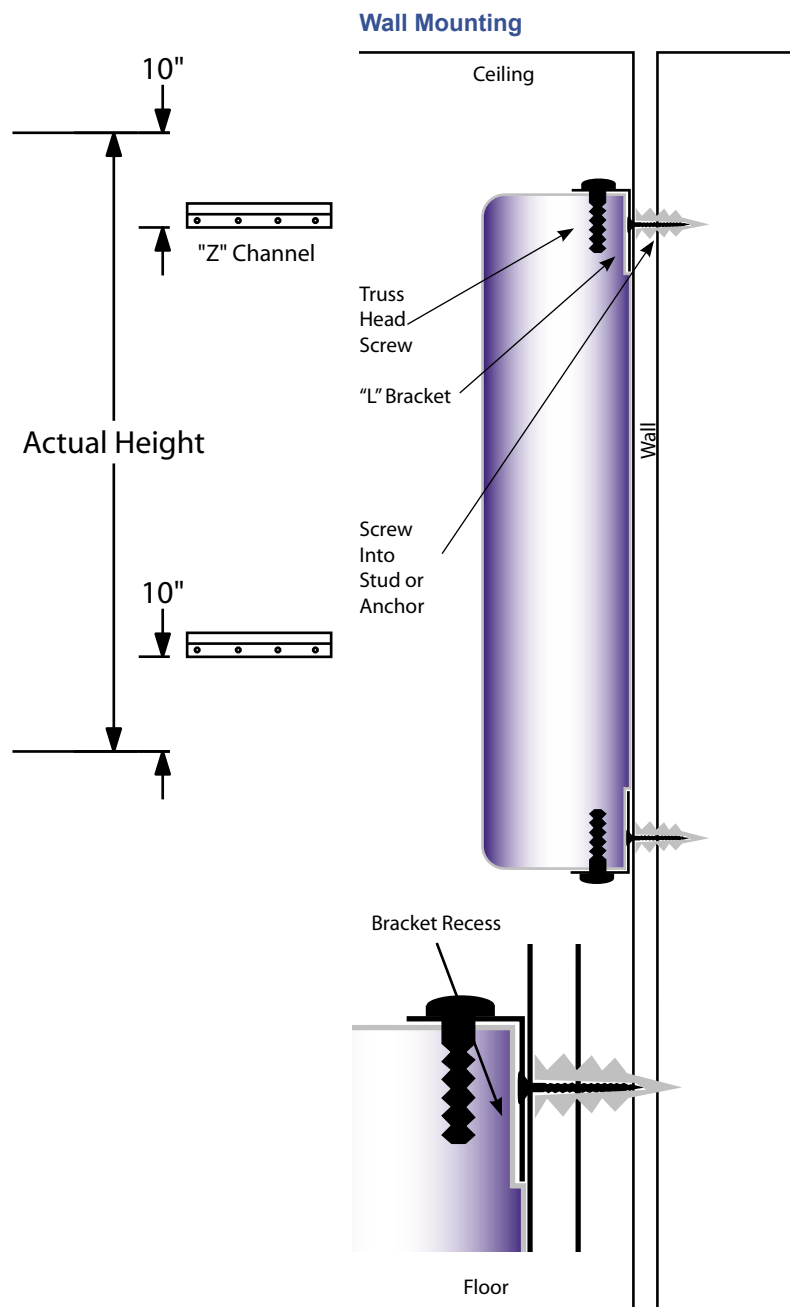

Wall Mounting